



# THREE PHASE PAD MOUNTED TRANSFORMER

ANSI, DOE, IEEE, CSA and IEC

# GENERAL

Daelim Belefic three phase pad mounted transformer is designed to use in underground distribution systems. Their sealed high-voltage and low-voltage safety compartments ensure their safe operation and reduce the risk of accidents, making them ideally suited for use in residential applications, tourist sites, hotels and other buildings. Pad mounted transformers are placed inside a cabinet with doors and locks, usually located outdoors.

These transformers come in two basic configurations: radial and loop feed, which are selected based on the type of circuit on which the transformers will be installed. The transformer uses aluminum or copper winding and is optimized to maximize efficiency and footprint.

The latest applicable standards (ANSI, DOE, IEEE, CSA and IEC) have been applied to all of Daelim Belefic transformers.

Daelim Belefic transformers are developed and produced especially to satisfy exacting customer's exact specification. We are continuously committed to providing high-quality products: high voltage, no drifting of neutral point, low loss, small volume, cost-effective, safety and environment protection, with attractive appearance, etc.

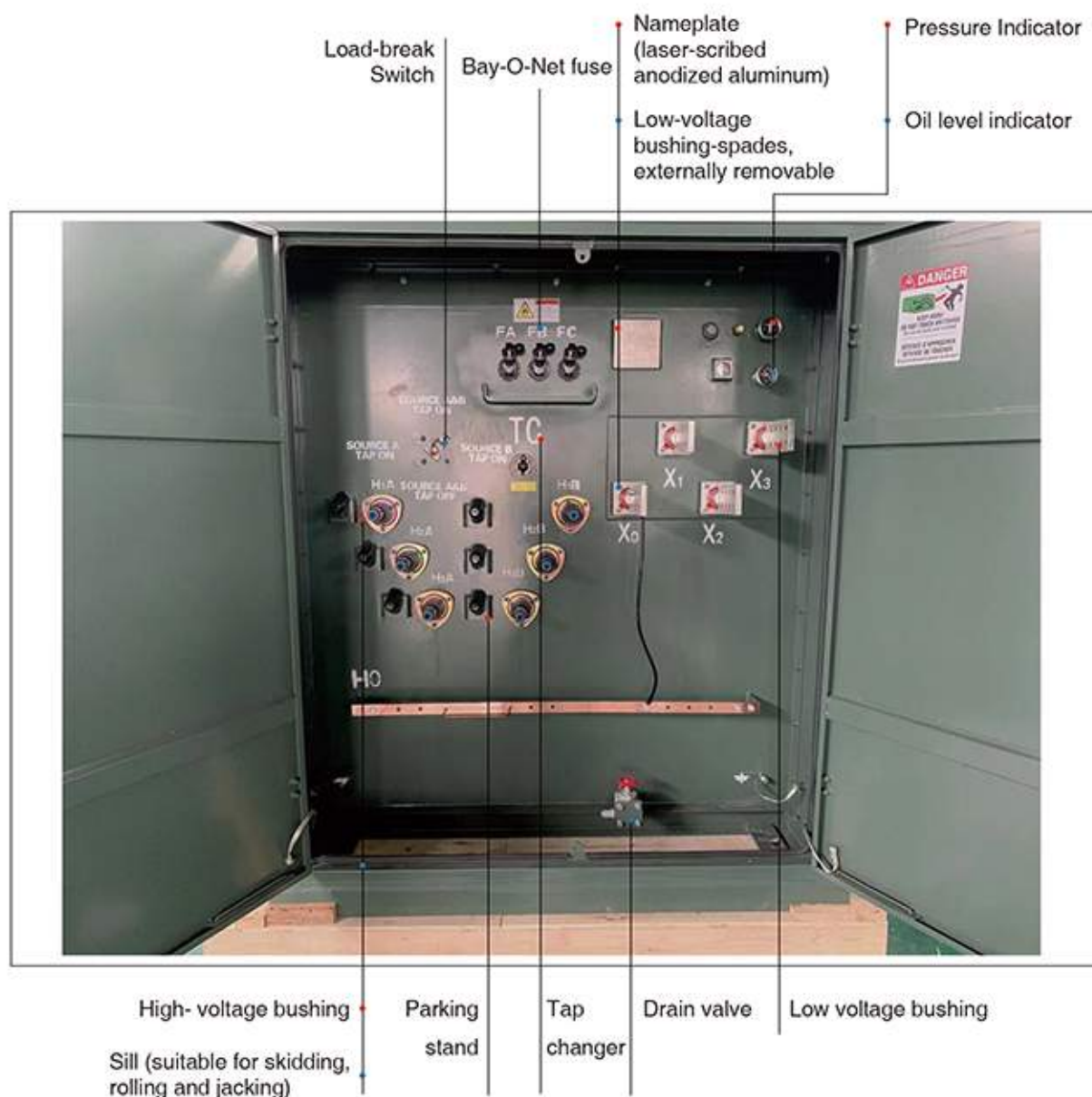

# 01 DESIGN CAPABILITY



- Mild steel, optional stainless steel tank
- Capacity: 10mva
- Primary Voltage: 2400-44000V
- Secondary Voltage: From 120Y/208V
- Loop or Radial Feed Configuration
- Insulation Fluids: Mineral Oil, Silicon Oil and FR3(Vegetable Oil)
- ANSI, DOE, IEEE, CSA and IEC

# 02 APPLICATION



- High efficiency design
- Special Ambient Design
- Low Sound Level Design
- 50 Hz and 60 Hz Design
- K-Factor Rating



## 03

## STANDARD FEATURE

- – Three-point latching door for security
- – Removable sill for easy installation
- – Stainless steel cabinet hinges and mounting studs
- – Bolted-on cabinet with removable sill having the following depths :
  - / 19" deep for 300kVA through 750 kVA
  - / 22" deep for 1000kVA through 1500kVA
  - / 24" deep for 2000 kVA through 3750kVA
  - / 30" deep for 5000 Kva through 7500kVA
- – For live front construction, externally clamped high voltage porcelain bushings with a single eyebolt, clamp-type connector (accommodates #6 AWG solid to 250 MCM stranded conductors).
- – For dead front construction, externally clamped high voltage bushing wells for loadbreak or non-loadbreak inserts.
- – HV and LV compartment doors-hinged and lift-off type with 120° holding bars
- – Steel HV/LV compartment barrier
- – Padlocking facility with one penta-head bolt on the LV compartment door and two penta-head bolts on the HV compartment door-including 3 point latching mechanism
- – HV connection:
  - / Live front-external clamped and removable HV bushings with eyebolt, clamp type connector
- – LV connection:
  - / Externally clamped polymer & porcelain LV bushing with 4-12 Hole spades
- – Oil drain plug for 500 kVA and below
- – 1" drain valve with sampler for 750 kVA and above
- – Oil fill plug
- – Five-legged core/coil assembly.
- – Removable LV neutral ground strap; as required
- – Nameplate per ANSI requirement
- – Self-actuating pressure relief valve
- – Lifting lugs (4)



## Standard Primary

Voltage Ratings	Minimum BIL(kV)
-----------------	-----------------

### Delta or Wye

2400	45
4160	60
4800	60
7200	75
7620	75
12000	95
12470	95
13200	95
13800	95
16340	95

### Ground Wye

4160GrdY/2400	65
12470GrdY/7200	95
13200GrdY/7620	95
13800GrdY/7970	95
22860GrdY/13200	125
23900GrdY/13800	125
24940GrdY/14400	125
34500GrdY/19920	150

## Standard kVA Ratings

45
75
112.5
150
225
300
500
750
1000
1500
2000
2500

For kVA not listed, please contact Daelim for customization.





## 04

## OPTIONAL ACCESSORIES

- - Oil level gauge
- - Liquid temperature gauge
- - Pressure vacuum gauge
- - Welded cover with handhole
- - Oil drain valve with or without sampler
- - Mechanical pressure relief device mounted on tank cover
- - Primary termination:
  - / Externally clamped bushing wells with loadbreak inserts
  - / Integral loadbreak or non-loadbreak bushings
- - Secondary termination:
  - / Externally clamped bushings with NEMA 4-hole, 6-hole, 8-hole, 10-hole or 12-hole spades
  - / Spade supports are available. They are provided for 8-hole spades and larger
- - Primary Switching:
  - / LBOR oil switch: one for radial feed.
  - / Externally operated de-energized tap changer
  - / Externally operated dual voltage switch
  - / Externally operated  $\Delta$ -Y switch
  - / 2-position loadbreak oil switches
  - / 4-position T or V blade sectionalizing loop switches
- - Overvoltage Protection:
  - / Distribution class, metal oxide arresters, 3-36 kV.
  - / Distribution class, valve-type lightning arresters, 3-27 kV.
- - Over-current protection:
  - / Bayonet-type expulsion fuses with plastic drip cup mounted on each bayonet fuse
  - / Weak link cartridge fuses
  - / Bayonet type in series with internal partial-range current limiting fuses
  - / Secondary under oil circuit breaker
- - Additional construction options:
  - / Stainless steel tank and cabinet design
  - / Partial stainless steel design (cabinet sill and tank bottom)
  - / 30" or 34" or 40" deep cabinet
  - / CT's or PT's, including mounting support
  - / LV externally mounted molded case breaker
  - / Externally mounted kWh meter
  - / Flip-top cabinet for low profile design
  - / Additional externally mounted nameplate
  - / Different paint color per requirement
- - Weathercover:
  - / Transformers may feature an optional weathercover over the cabinet which is hinged to allow clearance for replacement of the bayonet-type fuses.
  - / The weathercover can be lifted easily into place and secured with a single supporting arm.
  - / The weathercover requires no additional holddown hardware.



Bay-O-Net Fuse



Load Break Switch



Parking Stand



Drain Valve



Oil Level Indicator



Pressure Relief valve



Pressure Indicator



Tap Changer

## Radial Feed

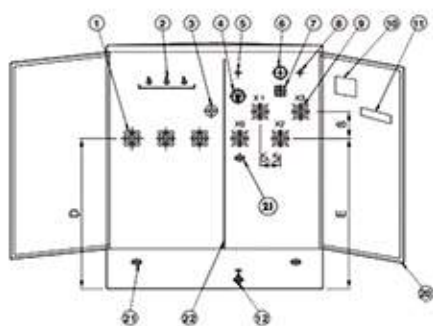
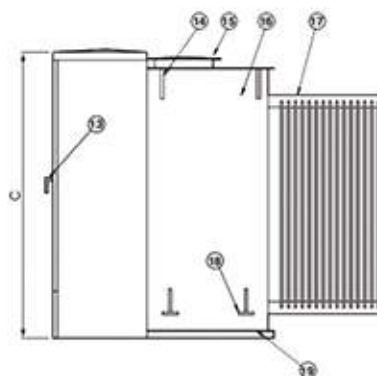
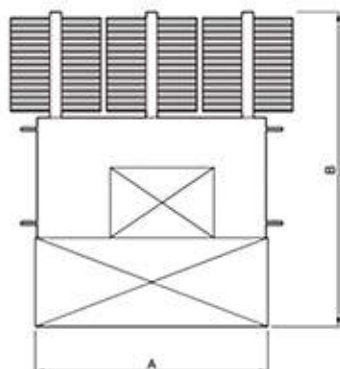

Dead Front  
Radial Feed

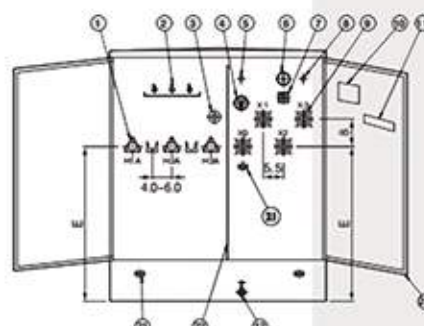

Live Front  
Radial Feed

NO.	NAME	NO.	NAME
1	HV BUSHING	12	DRAIN VALVE WITH SAMPLER
2	BAY-O-NET FUSE	13	DOOR HANDLE
3	TAP CHANGER	14	LIFTING LUG
4	DIAL TYPE THERMOMETER	15	HAND HOLE&SECURITY COVER
5	FILLING PLUG	16	TANK
6	PRESSURE VACUUM GAUGE	17	RADIATORS
7	OIL LEVEL GAUGE	18	JACKING PAD
8	PRESSURE RELIEF VALVE	19	JACKING PROVISIONS
9	LV BUSHING	20	DOOR
10	NAMEPLATE	21	GROUNDING PAD
11	WARNING LABEL	22	HV-LV BARRIER

RATING (KVA)	No Load Loss (W)	On Load Loss (W)	W (mm)	D (mm)	H (mm)	Oil Weight (L)	Total Weight (KG)
45	160	1000	1730	990	1270	416	950
75	180	1250	1730	990	1270	435	1020
112.5	200	1500	1730	1245	1270	454	1070
150	280	2200	1730	1245	1270	473	1225
225	400	3050	1830	1295	1270	530	1430
300	480	3650	1830	1295	1270	605	1655
500	680	5100	2260	1345	1270	720	2110
750	980	7500	2260	1448	1625	1022	2950
1000	1150	10300	2260	1500	1625	1325	3720
1500	1640	14500	2260	2190	1854	1552	4672
2000	2160	20645	1830	2210	1854	1855	5670
2500	2680	27786	1830	2515	1854	2006	6580

DAELIM

## Loop Feed

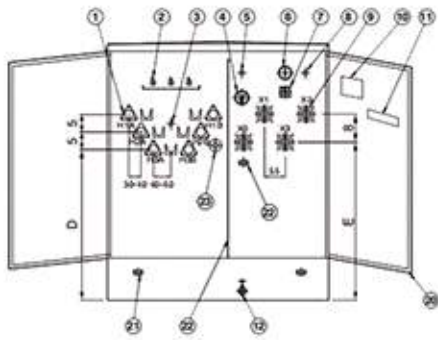
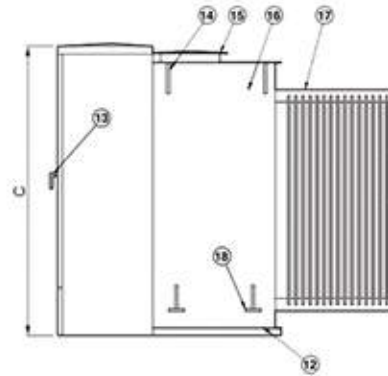
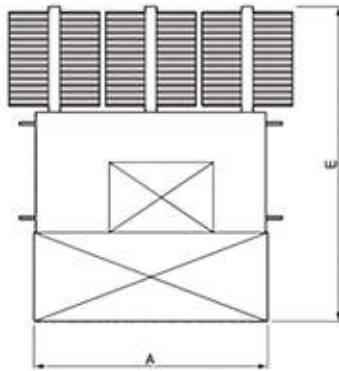

NO.	NAME	NO.	NAME
1	HV BUSHING	12	DRAIN VALVE WITH SAMPLER
2	BAY-O-NET FUSE	13	DOOR HANDLE
3	TAP CHANGER	14	LIFTING LUG
4	DIAL TYPE THERMOMETER	15	HAND HOLE&SECURITY COVER
5	FILLING PLUG	16	TANK
6	PRESSURE VACUUM GAUGE	17	RADIATORS
7	OIL LEVEL GAUGE	18	JACKING PAD
8	PRESSURE RELIEF VALVE	19	JACKING PROVISIONS
9	LV BUSHING	20	DOOR
10	NAMEPLATE	21	GROUNDING PAD
11	WARNING LABEL	22	HV-LV BARRIER

RATING (KVA)	No Load Loss (W)	On Load Loss (W)	W (mm)	D (mm)	H (mm)	Oil Weight (L)	Total Weight (KG)
45	160	1000	1730	990	1270	416	950
75	180	1250	1730	990	1270	435	1020
112.5	200	1500	1730	1245	1270	454	1070
150	280	2200	1730	1245	1270	473	1225
225	400	3050	1830	1295	1270	530	1430
300	480	3650	1830	1295	1270	605	1655
500	680	5100	2260	1345	1270	720	2110
750	980	7500	2260	1448	1625	1022	2950
1000	1150	10300	2260	1500	1625	1325	3720
1500	1640	14500	2260	2190	1854	1552	4672
2000	2160	20645	1830	2210	1854	1855	5670
2500	2680	27786	1830	2515	1854	2006	6580

DAELIM



# 05

## CONSTRUCTION

### CORE

The three-legged, step-lap mitered core construction is manufactured using a high-quality cutting machine. For maximum efficiency, cores are precisely stacked, virtually eliminating gaps in the corner joints.

Five-legged wound core or shell-type triplex designs are used for wye-wye connected transformers, and other special transformer designs.

Cores are manufactured with precision cut, burr-free, grain-oriented silicon steel. Many grades of core steel are available for optimizing core loss efficiency.

### COIL

Pad-mounted transformers feature a rectangular coil configuration with wire-wound, high-voltage primaries and sheet-wound secondaries. The design minimizes axial stress developed by short circuits and provides for magnetic balancing of tap connections.

Coils are wound using the highest quality winding machines providing exacting tension control and conductor placement for superior short-circuit strength and maximum efficiency.

Extra mechanical strength is provided by diamond pattern, epoxy coated paper insulation, used throughout the coil, with additional epoxy at heavy stress points. The diamond pattern distribution of the epoxy and carefully arranged ducts, provide a network of passages through which cooling fluid can freely circulate.

Coil assemblies are heat-cured under calculated hydraulic pressure to ensure performance against short-circuit forces.

### CORE AND COIL ASSEMBLIE

Pad-mounted transformer core and coil assemblies are braced with heavy steel ends to prevent the rectangular coil from distorting under short-circuit conditions. Plates are clamped in place using presses, and welded or bolted to form a solid core and coil assembly. Core and coil assemblies exceed ANSI® and IEEE® requirements for short-circuit performance. Due to the rigidity of the design, impedance shift after short-circuit is comparable to that of circular wound assemblies.

# 05

## CONSTRUCTION

### TANK

Transformer tanks are designed for high strength and ease of handling, installation, and maintenance. Tanks are welded using precision-cut, hot rolled, pickled and oiled steel. They are sealed to protect the insulating fluid and other internal components.

Transformer tanks are pressure-tested to withstand 7 psig without permanent distortion and 15 psig without rupture.

### TANK FINISH

An advanced multi-stage finishing process exceeds IEEE Std C57.12.28™-2005 standards. The eight-stage pre-treatment process assures coating adhesion and retards corrosion. It converts tank surfaces to a nonmetallic, water insoluble iron phosphate coating. The paint method consists of two distinct layers of paint. The first is an epoxy primer (E-coat) layer which provides a barrier against moisture, salt and corrosives. The two-component urethane final coat seals and adds ultraviolet protection.

### VACUUM PROCESSING

Transformers are dried and filled with filtered insulating fluid under vacuum, while secondary windings are energized. Coils are heated to drive out moisture, ensuring maximum penetration of fluid into the coil insulation system.

### INSULATING FLUID

Transformers from Daelim Belefic are available with electrical-grade mineral insulating oil or Envirotemp™ FR3™ fluid. The highly refined fluids are tested and degassed to assure a chemically inert product with minimal acid ions. Special additives minimize oxygen absorption and inhibit oxidation. To ensure high dielectric strength, the fluid is re-tested for dryness and dielectric strength, refiltered, heated, dried, and stored under vacuum before being added to the completed transformer.

Daelim Belefic transformers filled with Envirotemp™ FR3™ fluid enjoy unique fire safety, environmental, electrical, and chemical advantages, including insulation life extending properties.

A bio-based, sustainable, natural ester dielectric coolant, Envirotemp™ FR3™ fluid quickly and thoroughly biodegrades in the environment and is non-toxic per acute aquatic and oral toxicity tests.

# 05

## CONSTRUCTION

### 8 TEST

Daelim Belefic performs routing testing on each transformer manufactured including the following tests:

- **Ratio, Polarity, and Phase Relation:** Assures correct winding ratios and tap voltages; checks insulation of HV and LV circuits. Checks entire insulation system to verify all live-to-ground clearances.
- **Resistance:** This test verifies the integrity of internal high-voltage and low-voltage connections; provides data for loss upgrade calculations.
- **Applied Potential:** Applied to both high-voltage and low-voltage windings, this test stresses the entire insulation system to verify all live-to-ground clearances.
- **Induced Potential:** 3.46 times normal plus 1000 volts for reduced neutral designs.
- **Loss Test:** These design verification tests are conducted to assure that guaranteed loss values are met and that test values are within design tolerances. Tests include no-load loss and excitation current along with impedance voltage and load loss.
- **Leak Test:** Pressurizing the tank to 7 psig assures a complete seal, with no weld or gasket leaks, to eliminate the possibility of moisture infiltration or fluid oxidation.
- **Operation tests of all devices:** All electrical and electro-mechanical devices shall be operated both in auto and manual mode for proper sequencing/staging and function.

### DESIGN PERFORMANCE TEST

The design performance tests include the following:

- **Temperature Rise:** Our automated heat run facility ensures that any design changes meet ANSI® and IEEE® temperature rise criteria.
  - **Audible Sound Level:** Ensures compliance with NEMA® requirements.
  - **Lightning Impulse:** To assure superior dielectric performance, this test consists of one reduced wave, two chopped waves and one full wave in sequence, precisely simulating the harshest conditions.
- \*Other performance tests such as short-circuit capability test, lifting and moving devices test can be executed while specified by the customer.



**DB Transformer, with an Edge**



**CESI SGS**



Quality  
ISO 9001



Environment  
ISO 14001



Health & Safety  
ISO 45001



**DAELIM BELEFIC**

## CONTACT US

**TEL:** +86-10-65002471/65001715

**FAX:** +86-10-65001719

**CELL:** +86-17600626876 +86-13051965423

**EMAIL:** SERVICE@DAELIM-ELECTRIC.COM

**WEBSITE:** WWW.DAELIM-ELECTRIC.COM

**ADD:**

**BEIJING OFFICE:**

2707, No.4 BUSINESS BUILDING, CHINA CENTRAL PLACE, CHAOYANG DISTRICT, BEIJING, CHINA

**JIANGSU FACTORY:**

169 XINLOU ROAD, QUTANG TOWN, HAI'AN CITY, NANTONG CITY, JIANGSU PROVINCE



### Safety Instructions

- For your safety, please read user's manual thoroughly before operating.
- Contact the nearest authorized service facility for examination, repair, or adjustment.
- Please contact qualified service technician when you need maintenance.  
Do not disassemble or repair by yourself!
- Any maintenance and inspection shall be performed by the personnel having expertise